

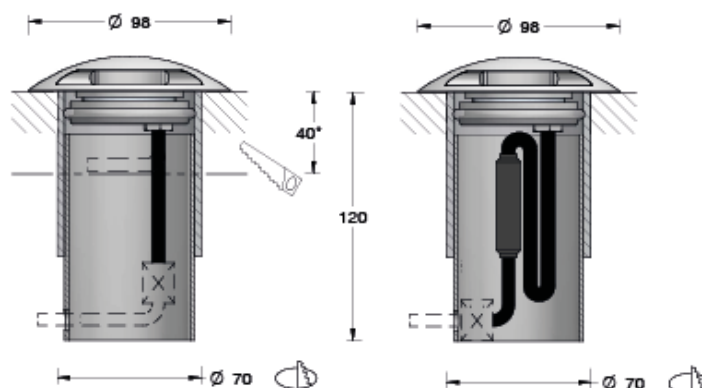

# VEGA BALISE MAXI

Ground recessed luminaire for beaconing  
(large beacon)



- . **Material:** Body : Stainless Steel 316L  
Dome : Stainless Steel 316L - Brass  
Tempered glass extra white
- . **Fixing :** Ground recessed
- . **LED Source :** 1 LED 3-SDCM - L90B10@100.000hr
- . **Color T° :** 2700K / 3000K / 4000K - Other possible temperatures, contact us.
- . **Product flux :** 41lm - 103lm (at 3000K)
- . **Efficacy :** 21lm/W
- . **CRI :** 80+ / 90+
- . **Optic :** Beacon (Clear glass)
  
- . **Adjustable :** No
- . **Dimensions :** Ø98mm
- . **Weight :** 0.50Kg
  
- . **Protection :** IP68
- . **Impact :** IK10
- . **Static load :** 4T
- . **High pressure :** No
  
- . **Protection :** Classe III
- . **Power :** 2.3W (monochrome) / 2.9W (monochrome)
- . **Power supply :** 700mA / 12-24VDC
- . **Driver :** Remote
- . **Control :** On-Off / 1-10V\* / DALI\* (with adequate driver)  
\*Optional control through smartphone bluetooth CASAMBI
- . **Cables :** 1ml standard (2x0.5mm<sup>2</sup> noir) - Monochrome
  
- . **Energy class:** G
  
- . **Norms :** NF-EN 60529/60598-1/60598-2-1/60598-2-3/60598-2-5/62471
- . **Warranty:** 2 years standard

