

RAMBARDE

Linear fixture for fitting in guard-rail

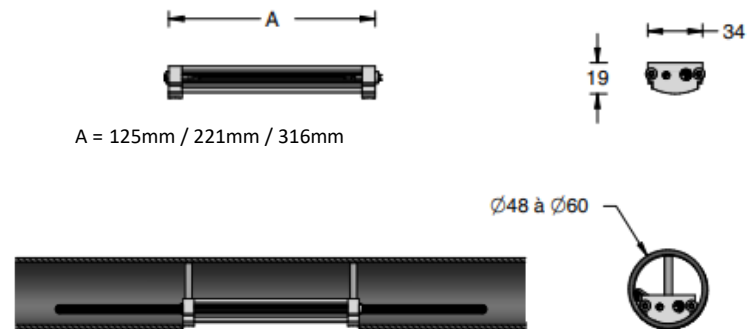
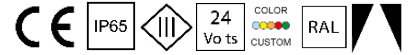

- . **Material:** Body in Anodized Aluminium (Epoxy paint possible)
PMMA glass
- . **Fixing :** Mechanical, non-intrusive, theft & vibration-proof inside handrail
- . **LED Source :** 3 / 6 / 9 LED 3-SDCM – L90B10@50.000hr
- . **Color T° :** 2700K / 3000K / 4000K - Other possible temperatures, contact us.
- . **Product flux :** 130lm – Low Power / 278lm – High Power (at 3000K-3LED-Asy_260)
- . **Efficacy :** 87 lm/W / 73 lm/W
- . **CRI :** 80+ / 90+
- . **Optic :** Special Asymetric

- . **Adjustable :** No
- . **Dimensions :** 125mm / 221mm / 316mm x 34mm x 19mm
- . **Weight :** 0.1 / 0.17 / 0.24 kg

- . **Protection :** IP65
- . **Impact :** -
- . **Static load :** -
- . **High pressure :** No

- . **Protection :** Classe III
- . **Power :** 1.5W->4.5W - LP / 3.8W->11W - HP
- . **Power supply :** 24VDC
- . **Driver :** Remote
- . **Control :** On-Off / 1-10V* / DALI* (with adequate driver)
*Optional control through smartphone bluetooth CASAMBI
- . **Cables :** 2x1ml standard (2x0.75mm² noir) - Monochrome

- . **Energy class:** F / G

- . **Norms :** NF-EN 60529/60598-1/60598-2-1/60598-2-3/60598-2-5/62471
- . **Warranty:** 2 years standard