

GEMINI MAX

Ground or ceiling recessed luminaire

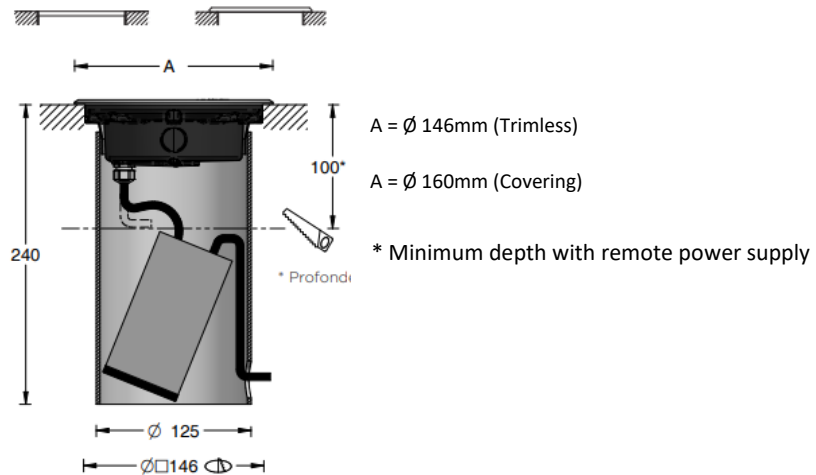

- . **Material:** Body in cast treated aluminium
Anodized Alum. - Stainless steel 316L - Brass (Epoxy paint possible)
Tempered glass extra white
- . **Fixing :** Recessed
- . **LED Source :** 9 LED 3-SDCM - L90B10@100.000hr
- . **Color T° :** 2700K / 3000K / 3500K / 4000K - Other possible temperatures, contact us.
RGB
- . **Product flux :** 1550lm (at 3000K-12°)
- . **Efficacy :** 123lm/W
- . **CRI :** 80+ / 90+
- . **Optic :** 12° / 24° / 30° / 50° / WW(12°x62°) / WW(24°x62°)
- . **Adjustable :** No
- . **Dimensions :** Ø 146mm ou 160mm
- . **Weight :** 1.7Kg
- . **Protection :** IP68
- . **Impact :** IK09
- . **Static load :** 1.1T
- . **High pressure :** No
- . **Protection :** Classe II / Classe III
- . **Power :** 16.8W
- . **Power supply :** 500mA / 240VAC
- . **Driver :** Remote
- . **Control :** On-Off / 1-10V* / DALI* / DMX* (with adequate driver)
*Optional control through smartphone bluetooth CASAMBI
- . **Cables :** 1ml standard (2x0.50mm² noir) - Monochrome
3ml standard (6x0.22mm² noir) - RGB
- . **Energy class :** E
- . **Norms :** NF-EN 60529/60598-1/60598-2-1/60598-2-3/60598-2-5/62471
- . **Warranty:** 2 years standard

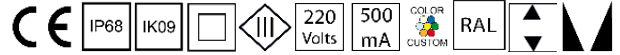