

GEMINI LAMP

Ground adjustable recessed LED lamp luminaire

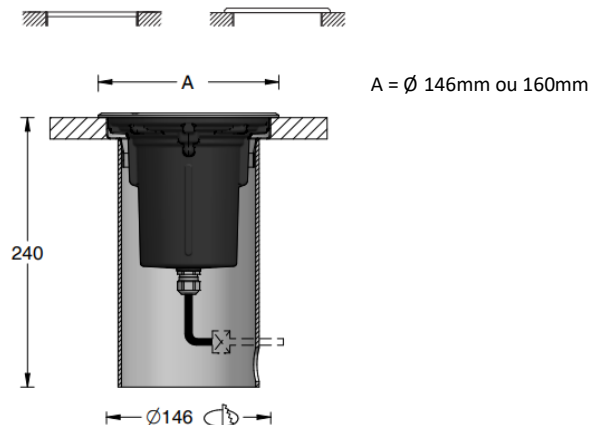
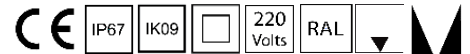

- . **Material:** Body in cast treated aluminium
- . **Disc:** Anodized Alum. - Stainless steel 316L - Brass (Epoxy paint possible)
- . **Fixing :** Tempered glass extra white
Ground recessed
- . **LED Source :** LAMP LED (GU10)
- . **Color T° :** Depending on the chosen LED lamp
- . **Product flux :** Depending on the chosen LED lamp
- . **Efficacy :** Depending on the chosen LED lamp
- . **CRI :** 80+ / 90+
- . **Optic :** LED lamp (Not Included)
- . **Adjustable :** Yes
- . **Dimensions :** Ø 146mm ou 160mm
- . **Weight :** 1.50Kg
- . **Protection :** IP67
- . **Impact :** IK09
- . **Static load :** 1.1T
- . **High pressure :** No
- . **Protection :** Classe II
- . **Power :** 7.5W
- . **Voltage :** 110-230 VAC
- . **Driver :** Included
- . **Control :** Depending on the chosen LED lamp
- . **Cables :** 1ml standard - (2x1mm² noir)
- . **Norms :** NF-EN 60529/60598-1/60598-2-1/60598-2-3/60598-2-5/62471
- . **Warranty:** 2 years standard